



Crazy Cart



OWNER'S MANUAL

Read and understand this entire manual before allowing child to use this product! For assistance contact Razor. DO NOT RETURN TO STORE.

NOTE: Manual illustrations are for demonstration purposes only. Illustrations may not reflect exact appearance of actual product. Specifications subject to change without notice.

Please have your 19 character product I.D. code ready before contacting Razor for warranty assistance and/or replacement parts.

Product I.D. Code: _____ - _____ - _____

CONTENTS

Safety Warnings	1-2	Troubleshooting Guide	8
Before You Begin	2	Crazy Cart Parts	9
Assembly and Set-Up / Pre-Ride Checklist.....	3	Warranty	11
How to operate the Crazy Cart.....	4-5		
Repair and Maintenance.....	6-7		

SAFETY WARNINGS

⚠ WARNING: The Crazy Cart is not the same as an “ordinary” go-kart and therefore may require greater skill to ride than an ordinary go-kart. The Crazy Cart is designed to allow movement forward, backward, laterally, in drifting arcs and even to pivot around in circles. Using this product requires flat open space, free of other traffic or obstacles, and it is best ridden by a practiced driver aware of the product’s capabilities and willing to accept risks associated with quick turns and fast moving actions.

⚠ WARNING: Riding any electric product can be a hazardous activity. Certain conditions may cause the equipment to fail without fault of the manufacturer. Like other electric products, the Crazy Cart can and is intended to move, and it is therefore possible to lose control, fall off and/or get into dangerous situations that no amount of care, instruction or expertise can eliminate. If such things occur you can be seriously injured or die, even when using safety equipment and other precautions. **RIDE AT YOUR OWN RISK AND USE COMMON SENSE.**

⚠ WARNING: PARENTAL AND ADULT RESPONSIBILITY AND SUPERVISION NECESSARY: Because products, like Crazy Cart, can and do present potential hazards plainly associated with their use, it is well recognized THE NEED FOR EXERCISE OF PARENTAL RESPONSIBILITY IN SELECTING RIDING PRODUCTS APPROPRIATE TO THE AGE OF A CHILD, OR PARENTAL SUPERVISION IN SITUATIONS IN WHICH CHILDREN OF VARIOUS AGES MAY HAVE ACCESS TO THE SAME RIDING PRODUCTS, IS IMPORTANT. Not every product is appropriate for every age or size of child, and different age recommendations are found within this category of product which are intended to reflect the nature of the hazards and the expected mental or physical ability, or both, of a child to cope with the hazards.

This manual contains many warnings and cautions concerning the consequences of failing to maintain, inspect or properly use your electric product. Because any incident can result in serious injury or even death, we do not repeat the warning of possible serious injury or death each time such a possibility is mentioned.

APPROPRIATE RIDER USE AND PARENTAL SUPERVISION

This manual contains important safety information. It is your responsibility to review this information and make sure that all riders understand all warnings, cautions, instructions and safety topics, and assure that young riders are able to safely and responsibly use this product. Razor USA recommends that you periodically review and reinforce the information in this manual with younger riders, and that you inspect and maintain your children’s product to insure their safety.

The recommended rider age of 9 years or older is only an estimate and can be affected by the rider’s size, weight or skills. Any rider unable to fit comfortably on the Crazy Cart should not attempt to ride it. **A parent’s decision to allow his or her child to ride this product should be based on the child’s maturity, skill, and ability to follow rules.**

DO NOT EXCEED THE WEIGHT LIMIT OF 140 lb (63 kg). Rider weight does not necessarily mean a person’s size is appropriate to fit or maintain control of the Crazy Cart.

Keep this product away from small children and remember that this product is intended for use only by persons who are, at a minimum, completely comfortable and competent while operating the product.

Persons with any mental or physical conditions that may make them susceptible to injury, impair their physical dexterity or mental capabilities to recognize, understand, and follow safety instructions and to be able to understand the hazards inherent in a product’s use, should not use or be

permitted to use products inappropriate for their abilities. Persons with heart conditions, head, back or neck ailments (or prior surgeries to these areas of the body), or pregnant women, should be cautioned not to operate this product.

Do not touch the electric motor on your product when in use as it can become very hot.

CHECK AND MAINTAIN CRAZY CART

Before use, check to confirm that any and all chain guards or other covers and guards are in place and in serviceable condition. Check that the parts are functioning properly, that the main driving tire is inflated properly and has sufficient tread remaining. The Crazy Cart should be maintained and repaired in accordance with the manufacturer’s specifications, using only the manufacturer’s authorized replacement parts, and should not be modified from the manufacturer’s original design and configuration. Replace worn or broken parts immediately.

ACCEPTABLE RIDING PRACTICES AND CONDITIONS

Always check and obey any local laws or regulations which may affect the locations where the Crazy Cart may be used. Ride defensively. Watch out for potential obstacles that could catch your wheel or force you to swerve suddenly or lose control. Be careful to avoid pedestrians, skaters, skateboards, scooters, bikes, children or animals who may enter your path, and respect the rights and property of others.

The Crazy Cart is meant to be used on private property and on closed courses, and not on public streets or sidewalks. Do not ride your electric product in any areas where pedestrian or vehicle traffic is present.

Do not activate the foot pedal throttle unless you are seated and in a safe, outdoor environment suitable for riding, with the seat belt fastened.

This product was manufactured for performance and durability, but is not impervious to damage. Bumping into obstacles, jumping or other aggressive riding can overstress and damage any product, including the Crazy Cart, and the rider assumes all risks associated with high-stress activity.

Be careful and know your limitations. Risk of injury increases as the degree of riding difficulty increases. The rider assumes all risk associated with aggressive riding activities.

Maintain a hold on the steering wheel at all times.

Never carry passengers or allow more than one person at a time to ride the electric product.

Never use near steps or swimming pools.

Keep your fingers and other body parts away from the drive chain, steering system, wheels and all other moving components.

Never use headphones or a cell phone when riding.

Never hitch a ride with another product.

Do not ride the Crazy Cart in wet or icy weather and never immerse the electric product in water, as the electrical and drive components could get damaged by water or possibly create other unsafe conditions.

Wet, slick, bumpy, uneven or rough surfaces may increase risks. Do not ride the electric product in mud, ice, puddles or water. Avoid excessive speeds that can be associated with downhill rides. Never risk damaging surfaces, such as carpet or flooring, by using an electric product indoors.

Do not ride at night or when visibility is limited.

SAFETY WARNINGS

PROPER RIDING ATTIRE

Always wear proper protective equipment, such as an approved safety helmet (with chin strap securely buckled). A helmet may be legally required by local law or regulation in your area. Elbow pads and kneepads, a long-sleeved shirt, long pants and gloves are recommended. Always wear athletic shoes (lace-up shoes with rubber soles), never ride barefooted or in sandals, and keep shoelaces tied and out of the way of the wheels, motor, and drive system.

USING THE CHARGER

The charger supplied with the Crazy Cart should be regularly examined for damage to the cord, plug, enclosure and other parts. In the event of such damage, the Crazy Cart must not be charged until the charger has been repaired or replaced.

Use only with the recommended charger.

Use caution when charging.

The charger is not a toy. Charger should be operated by an adult.

Do not operate charger near flammable materials.

Unplug charger and disconnect from Crazy Cart when not in use.

Do not exceed charging time.

Always disconnect from the charger prior to wiping down and cleaning your Crazy Cart with damp cloth.

**FAILURE TO USE COMMON SENSE AND HEED THE WARNINGS INCREASES RISK OF SERIOUS INJURY.
USE WITH APPROPRIATE CAUTION AND SERIOUS ATTENTION TO SAFE OPERATION.**

BEFORE YOU BEGIN

Remove contents from box. Remove the foam separators that protect the components from damage during shipping. Inspect the contents of the box for scratches in the paint, dents or kinked cables that may have occurred during shipping. Because the Crazy Cart was 99 percent assembled and packed at the factory, there should not be any problems, even if the box has a few scars or dents.

Estimated Assembly and Set-Up Time

Razor recommends assembly by an adult.

Allow up to 5 minutes for assembly, not including initial charge time.

Allow up to 12 hours for initial charge (see page 3 for charging information).

Charger

(Note: Charger design may vary from one shown)

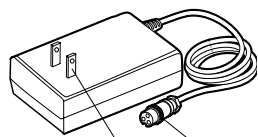

Charger Plug Charger Port

Steering Wheel

Speed Control / Accelerator Pedal

Charger Port

On/Off Switch

Drift Bar

Safety belt

Safety Button

Required Tool

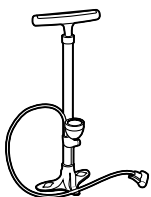

Bicycle tire pump for Schrader valves, with pressure gauge (Not Included)

WARNING:

DO NOT USE NON-RAZOR PARTS WITH YOUR CRAZY CART.

The Crazy Cart has been built to certain Razor design specifications. The original equipment supplied at the time of sale was selected on the basis of its compatibility with the frame and all other parts. Certain aftermarket components may not be compatible. Use of non-Razor parts will void the warranty.

WARNING:

Turn power switch off before conducting any assembly or maintenance procedures.

Product ID Locations:

1. Frame
2. Charger
3. Box (not shown)

NOTICE: The safety belt arrangement supplied with the Crazy Cart is not intended for use in larger, faster vehicles and is for "play" use only. It is not an ASTM-approved safety belt system and is not intended to function as an approved lap/shoulder/seat restraining device.

Need Help? Visit our website for replacement parts and product support at www.razor.com or call toll-free at 866-467-2967 Monday - Friday 8:00 AM - 5:00 PM Pacific Time. Please have the product I.D. code (located on the bottom of the frame) available for better assistance.

ASSEMBLY AND SET-UP

Turn power switch off before conducting any maintenance procedures.

❑ Charging the Battery

Your Crazy Cart may not have a fully charged battery; therefore you must charge the battery prior to use.

- Initial charge time: 12 hours.
- Recharge time: up to 12 hours, even if the light turns green. Recommended maximum charging time is 24 hours.
- Always charge the battery immediately after riding.
- Fully charge battery before storing for extended periods of time.
- Unplug charger from the wall outlet when not in use.
- Failure to recharge battery periodically may result in a battery that will not accept a charge.
- Make sure the Crazy Cart's power switch is turned **OFF** when unit is not in use. If the power switch is

left on for an extended period of time, the battery may reach a stage at which it will no longer hold a charge.

- To ensure long battery life, never store the product in freezing or below freezing temperatures! Freezing will permanently damage the battery.
- Run time: Up to 40 minutes of continuous ride time. Run time may vary depending on riding conditions, rider weight, climate, and/or proper maintenance.
- Average battery life for a properly maintained unit is approximately 250 charge/discharge cycles.

Charger

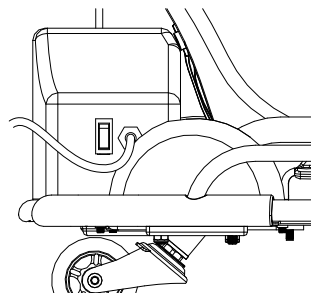
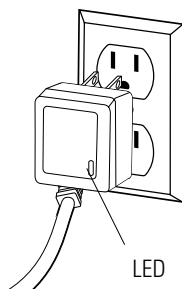
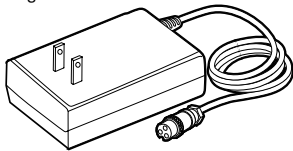

Note: Make sure power is turned **OFF** when unit is not in use. If the power switch is left on for an extended period of time, the battery may reach a stage at which it will no longer hold a charge.

1 Plug the charger plug into wall outlet. The light on the charger should be green.

Note: If green light (LED) does not turn on, try a different outlet

2 Plug the charger into the charger port on the Crazy Cart. Make sure the power switch is in the "OFF" position. The light on the charger should turn red during charging. The light will turn green again when charging is complete.

❑ Inflating the Tire

Tire is inflated when shipped, but it will invariably lose some pressure between the point of manufacturing and your purchase. **Always inflate tire to the correct PSI before first time use.**

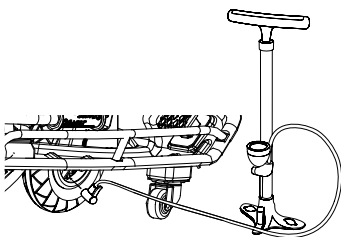

Using a bicycle style tire pump equipped for a Schrader-type valve, inflate the front tire to the PSI indicated on the sidewall of the tire.

⚠ WARNING: Use **ONLY** with the recommended charger. Batteries are only to be charged under adult supervision. The charger is not a toy. Always disconnect the charger before wiping down and/or cleaning the Crazy Cart with a damp cloth.

The charger supplied with the Crazy Cart should be regularly examined for damage to the cord, plug, enclosure and other parts. In the event of such damage, the Crazy Cart must not be charged until it has been repaired or replaced.

Chargers have built-in over-charge protection to prevent battery from being over-charged.

Note: If the charger gets warm during regular use, this is a normal response and is no cause for concern. If your charger does not get warm during use, it does not mean that it is not working properly.

Wall outlet - Green
Wall outlet and Unit - Red
Charging complete - Green

Note: Continue charging unit even if light turns green prior to 12 hours.

⚠ WARNING: Do not over inflate, as this could damage tire or wheel.

Note: The pressurized air supplies found at gasoline stations are designed to inflate high-volume automobile tires. If you decide to use such an air supply to inflate your Crazy Cart tire, first make sure the pressure gauge is working, then use very short bursts to inflate to the correct PSI. If you inadvertently over-inflate the tire, release the excess pressure immediately.

PRE-RIDE CHECKLIST



Loose Parts

Check and secure all fasteners before every ride. There should not be any unusual rattles or sounds from loose parts or broken components. If you are not sure, ask an experienced mechanic to check.



Frame, Fork and Steering Wheel

Check for cracks or broken connections. Although broken frames are rare, it is possible for an aggressive rider to run into a curb or wall and wreck, bend or break a frame. Get in the habit of inspecting the Crazy Cart before every ride.



Wheels

Practice drift riding only in wide open areas clear from curbs, parking blocks and other obstacles. Impacting the wheels against any hard surface can damage the wheels. Wheels are not covered under your limited warranty.



Safety Gear

Always wear proper protective equipment, such as an approved safety helmet. Elbow pads and kneepads are recommended. Always wear shoes (lace-up shoes with rubber soles), never ride barefooted or in sandals, and keep shoelaces tied and out of the way of the wheels, motor, and drive system.

HOW TO OPERATE THE CRAZY CART

Before you ride this exciting new product, take the time to learn about how it moves the way it moves. Familiarize yourself with these riding hints and tips so that your experiences with the Crazy Cart and allow you to maximize fun while keeping in control.

Notice: This product is equipped with a safety button that will not allow the accelerator pedal to engage until the button is depressed, even if the power switch is "on". Make sure rider is safely seated with safety belt in place prior to depressing safety button.

After riding, but before exiting the cart, press to release the button and re-engage safety feature. **Note:** Turning the power switch "off" will not re-engage the safety button.

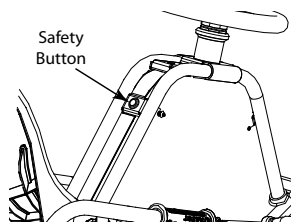

Four Important Control Features:

Accelerator Pedal, Steering Wheel, Drift Bar System, "Turn-Away" Stopping

The Crazy Cart allows really creative drifting, spinning and turning that no ordinary go-kart can do. If you have ridden a Razor RipStik® or a Razor RipRider 360®, think about those caster wheels and how they allow rapid changes of direction; or how a Razor Ground Force® Drifter™ go-kart allows full speed rear-end drifting. The Crazy Cart builds on these motions and adds even tighter turning possibilities through the fully rotational center motor and an adjustable angling ability for the rear caster wheels. Practice with these Crazy Cart characteristics can lead to amazing fun, and the importance of exercising caution and common sense when riding is – as with all moving products – important for every rider.

Accelerator Pedal

The Crazy Cart has a foot pedal accelerator that controls the cart's speed. This variable speed accelerator allows you to drive the cart at a range of speeds from 0-12 MPH, depending on how much it is depressed. This ability to dynamically speed up and slow down is the key to controlled drifting.

Steering Wheel

The Crazy Cart's steering wheel is different from a normal car or cart in a number of ways. The most important thing to remember about the Crazy Cart's steering wheel is that the arrow on it points in the direction where the cart is going to travel, regardless of how the rest of the cart is oriented. Simply point the arrow where you want the cart to go (using the drift bar can change how the back of the Crazy Cart follows, as described below).

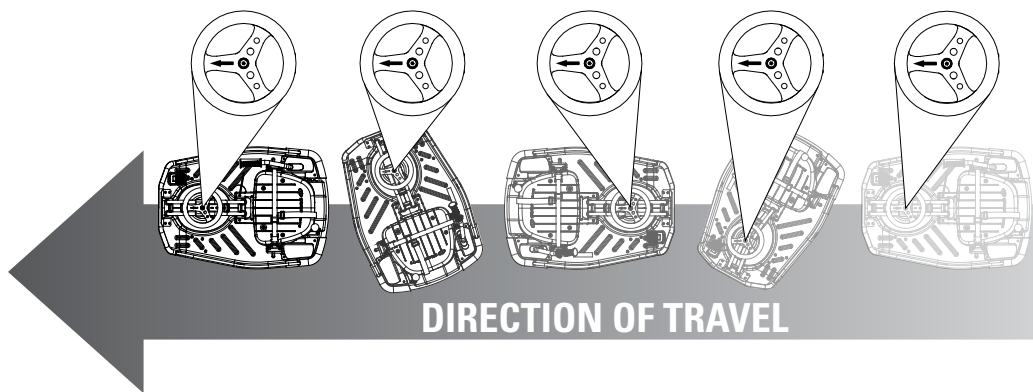

The Crazy Cart's steering wheel is able to rotate more than 180° in each direction. The steering wheel has a "hard stop" when it has reached the limit of its turning – it won't keep going around all the way, but by turning fully one direction or fully the other direction, you can ride the Crazy Cart backwards - and by turning at or near 90° the Crazy Cart can go in a very, very tight circle (be careful to avoid losing control by turning so much as to risk becoming dizzy).

The steering configuration of the Crazy Cart's integrated drive and steering mechanism is reminiscent of what some might call "shopping cart" design. It has no self-correcting camber or castering features (meaning the steering tube goes straight up and down so the wheel doesn't "align" itself on its own). Such steering might, in certain circumstances, shimmy or vibrate a little -- this is normal. Usually it is the result of an uncoordinated or adverse control condition. If you feel a shimmy in the steering, a change of direction and/or speed change helps reestablish smooth control.

IMPORTANT: Always select a riding area that is level, smooth, dry, and completely free of traffic or obstacles.

Riding Tip: Learning when to push and when to let off of the accelerator pedal will improve your ability to do spins, drifts, and tricks smoothly.

Need Help? Visit our website for replacement parts and product support at www.razor.com or call toll-free at 866-467-2967 Monday - Friday 8:00 AM - 5:00 PM Pacific Time. Please have the product I.D. code (located on the bottom of the frame) available for better assistance.

HOW TO OPERATE THE CRAZY CART

Drift Bar for Adjustable Rear Casters

The rear wheels on the Crazy Cart are mounted on casters, like RipStik wheels. By altering the angle of the support for these wheels, the Crazy Cart can either “track” in the same direction as the drive wheel is going or allow the rear end to “drift” in response to turning or acceleration forces. The drift bar allows control between the two driving modes: normal mode for straight tracking (down or default) and Crazy Cart mode for drifting (when the drift bar is pulled up). When the bar is in the down position, the Crazy Cart will track in-line with the front wheel like a traditional vehicle. As the drift bar is raised, it changes the angle of the rear casters and allows the rear of the cart to drift. The more the bar is raised, the easier the cart drifts. When the bar is all the way up, the casters are in “Crazy Cart mode.”

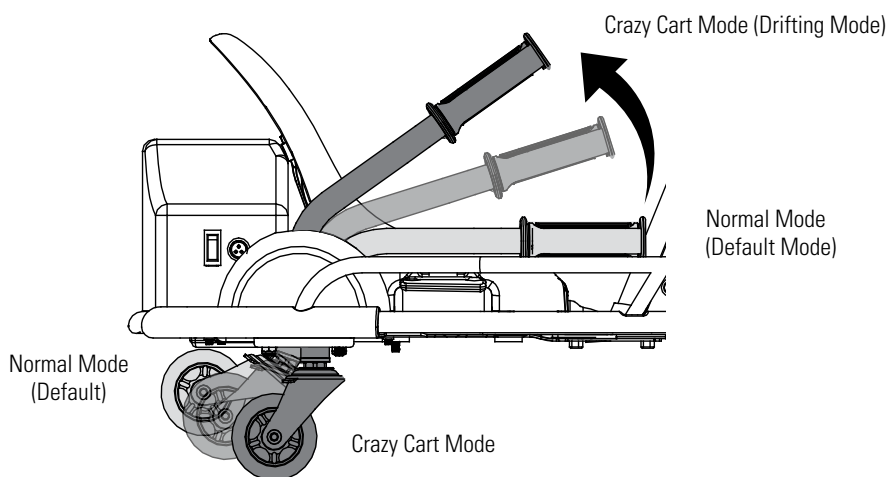

Riding Tip: With the steering wheel at 90°, the Crazy Cart will move in a circle using the rear inside caster as the “pivot point” if the drift bar is down -- but will rotate around its center if the drift bar is fully raised.

In Crazy Cart mode, the frame is able to rotate any direction, regardless of the direction of travel. In the Crazy Cart mode it is possible to drive in a straight line with the frame oriented any direction, including backwards and sideways.

The best use of the Cart involves careful coordination of the steering, the drift bar, and the accelerator. The majority of spins and drifts that can be done in the Crazy Cart are accomplished by careful accelerator control. Learning when to add or reduce power is the key to smoothly connecting tricks. Smooth riding also increases the run time between charges. When first getting oriented with the Crazy Cart, it is highly recommended that riders carefully apply the accelerator and take time to get familiar with the variable effects of the drift bar and steering at low speeds.

Stopping the Crazy Cart

While there is no brake on the Crazy Cart, removing your foot from the accelerator will slow the cart down as a result of friction in the drive train. To stop the cart, take your foot off of the accelerator and turn the steering wheel to either side. Removing your foot from the accelerator and turning the steering wheel will result in the Crazy Cart spinning or drifting in a circle and slowing to a stop. The size of the circle the cart will spin in depends on how much, if any, the drift bar is pulled up. The higher the drift bar is, the tighter the circle the cart will spin in.

By turning the steering wheel 90° and taking your foot off the pedal, the rider can immediately arrest forward motion and instead turn away. In this way, the Crazy Cart can avoid collisions and evade things otherwise in its path.

For your safety, take the time to get familiar and comfortable with various combinations of throttle, steering, and drift bar applications to learn how to slow down and how using the drift bar affects stopping at slow speeds. Practice these skills for maximum rider safety.

⚠ WARNING: Recognize that these specialized riding features affect how the Crazy Cart functions and require extra caution and attention to safe riding conditions and practices. Read and review the Riding Warnings, and be extra careful with this Crazy Cart to avoid traffic, obstacles and downhill environments. This is not a “bumper car” and is not designed to engage in collisions, jumping activities or for use on surfaces other than hardened, smooth, flat and dry areas.

REPAIR AND MAINTENANCE

Turn power switch off before conducting any maintenance procedures.

□ Front Wheel/Chain Replacement

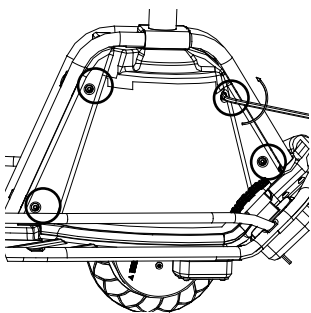

1 Using a Phillips screw driver, remove the four (4) screws on the right side of the motor cover (side of the foot pedal throttle) and remove cover.

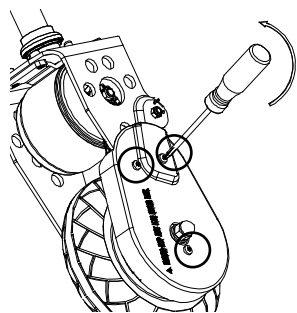

2 Using a Phillips screw driver, remove the three (3) screws on the chain guard and remove the chain guard.

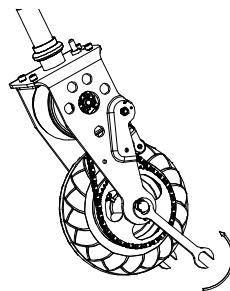

3 Using two (2) 16 mm wrenches, remove the locknuts on the front axle bolt and slide axle bolt out from the front wheel. Carefully remove the chain from around the wheel sprocket and remove wheel from the front fork. If replacing the chain, also remove the chain from around the motor shaft. Install replacement wheel/chain.

⚠ WARNING: Failure to properly install and tighten the screws, nuts and bolts that affix the steering wheel and seat can cause you to lose control and crash.

Note: Front wheel hardware sequence

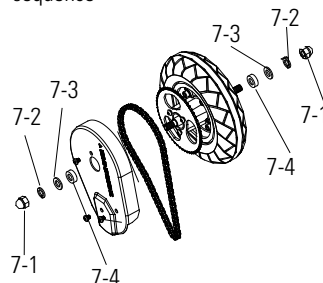

Right Side (Throttle)

- 7-1 Locknut
- 7-2 Split Washer
- 7-3 Flat Washer

Fork

- 7-4 Spacer

Left Side (Brake)

- 7-1 Locknut
- 7-2 Split Washer
- 7-3 Flat Washer

Fork

- 7-4 Spacer

□ Rear Wheels/Rear Casters Replacement

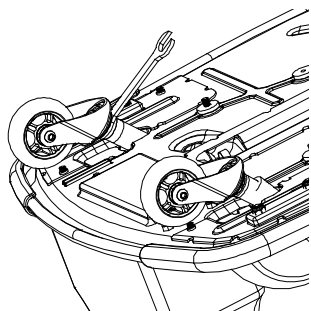

1 Carefully flip unit upside down and using a 24 mm wrench; loosen nut on the caster and remove caster.

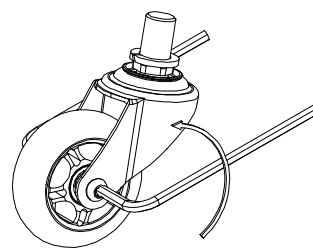

2 Using two (2) 5 mm Allen wrenches; loosen coupling bolt and remove wheel. Install the wheel into replacement caster. Install replacement caster on the Crazy Cart and tighten securely.

⚠ WARNING: Failure to properly adjust and tighten the screws, nuts and bolts that affix the wheels can cause you to lose control and crash.

Note: Practice riding only in wide open areas clear from curbs, parking blocks and other obstacles. Impacting the wheels against any hard surface can damage the wheels. Wheels are not covered under your limited warranty.

Need Help? Visit our website for replacement parts and product support at www.razor.com or call toll-free at 866-467-2967 Monday - Friday 8:00 AM - 5:00 PM Pacific Time. Please have the product I.D. code (located on the bottom of the frame) available for better assistance.

REPAIR AND MAINTENANCE

Battery Care and Disposal

Do not store in freezing or below freezing temperatures. To properly maintain your battery and ensure maximum battery life, carefully read the "Charging the Battery" section on page 3 of this owner's manual.



CONTAINS SEALED LEAD ACID BATTERIES. BATTERIES MUST BE RECYCLED.

Disposal: Your Razor product uses sealed lead-acid batteries which must be recycled or disposed of in an environmentally safe manner. Do not dispose of a lead-acid battery in a fire. The battery may explode or leak. Do not dispose of a lead-acid battery in your regular household trash. The incineration, land filling or mixing of sealed lead-acid batteries with household trash is prohibited by law in most areas. Return exhausted batteries to a federal or state approved lead-acid battery recycler or a local seller of automotive batteries. If you live in Florida or Minnesota, it is prohibited by law to throw away lead-acid batteries in the municipal waste stream.

Charger

The charger supplied with the Crazy Cart should be regularly examined for damage to the cord, plug, enclosure and other parts, and in the event of such damage, the product must not be charged until it has been repaired or replaced.

Use ONLY with the recommended charger.

Wheels

Wheels and drive system are subject to normal wear and tear. It is the responsibility of the user to periodically inspect wheels for excess wear and adjust and replace drive train components as required.

Replacement Parts

The most frequently requested replacement parts are available for purchase at some Razor retail partners. For the complete selection of replacement parts visit www.razor.com/shop.

Repair Centers

For a list of authorized Razor repair centers:

- Check online at www.razor.com.
- Call 866-467-2967 for the center nearest you.

⚠ WARNING: If a battery leak develops, avoid contact with leaking acid and place the damaged battery in a plastic bag. Refer to the disposal instructions at left. If acid comes into contact with skin or eyes, flush with cool water for at least 15 minutes and contact a physician.

⚠ WARNING: Battery posts, terminals and related accessories contain lead and lead compounds. **Wash your hands after handling.**

TROUBLESHOOTING

Problem	Possible Cause	Solution
Product does not run.	Undercharged battery.	Charge the battery. A new battery should have been charged for at least 12 hours before using the product for the first time and up to 12 hours after each subsequent use.
	Safety button is not depressed.	Depress safety button. Check all connectors. Make sure the charger connector is tightly plugged into the charging port and that the charger is plugged into a functioning wall outlet.
	Charger is not working.	Contact Razor Customer Service to get replacement charger.
Product was running but suddenly stopped.	Loose wires or connectors.	Check all wires and connectors to make sure they are tight.
Short run time.	Undercharged battery.	Charge the battery. A new battery should have been charged for at least 12 hours before using the product for the first time and up to 12 hours after each subsequent use.
	Battery is old and will not accept full charge.	Even with proper care, a rechargeable battery does not last forever. Average battery life is 1 to 2 years depending on product use and conditions. Replace only with a Razor replacement battery.
Product runs sluggishly.	Riding conditions are too stressful.	Use only on solid, flat, clean and dry surfaces such as pavement or level ground.
	Product is overloaded.	Make sure you do not overload the product by allowing more than one rider at one time, exceeding the maximum weight limit, going up too steep a hill or towing objects behind the product.
Sometimes the product doesn't run, but other times it does.	Loose wires or connectors.	Check all wires connectors to make sure they are tight.
	Motor or electrical switch damage.	Contact your local Razor authorized service center for diagnosis and repair. Contact Razor customer service or visit www.razor.com .
Charger gets warm during use.	Normal response to charger use.	No action required. This is normal for some chargers and is no cause for concern. If your charger does not get warm during use, it does not mean that it is not working properly.
Product makes loud noises or grinding sounds.	Chain is too dry.	Apply a lubricant such as 3 in 1™ or Tri-Flow™ to the chain.

For more troubleshooting tips, visit our website at www.razor.com.

Need Help? Visit our website for replacement parts and product support at www.razor.com or call toll-free at 866-467-2967 Monday - Friday 8:00 AM - 5:00 PM Pacific Time. Please have the product I.D. code (located on the bottom of the frame) available for better assistance.

CRAZY CART PARTS

Keep your Crazy Cart running for years with genuine Razor parts. Visit our web site or e-mail us for more information on spare part availability. (Specifications subject to change without notice.)

- | | | |
|-----------------------------|---------------------------|-----------------------------------|
| 1. Incline Protect Wheel | 10. Headset (Upper/Lower) | 19. On/Off Switch |
| 2. Chain | 11. Steering Wheel | 20. Base Cover (Right/Left) |
| 3. Chain Tensioner | 12. Safety Belt | 21. Rear Axle/Drift Bar |
| 4. Chain Guard | 13. Seat | 22. Rear Caster |
| 5. Front Fork | 14. Safety Button | 23. Rear Wheels |
| 6. Motor | 15. Control Module | 24. Protector Sleeve (Right/Left) |
| 7. Front Wheel | 16. Battery with Fuse | 25. Flag (not shown) |
| 8. Motor Cover (Right/Left) | 17. Battery Cover | |
| 9. Accelerator Pedal | 18. Charger Port | |

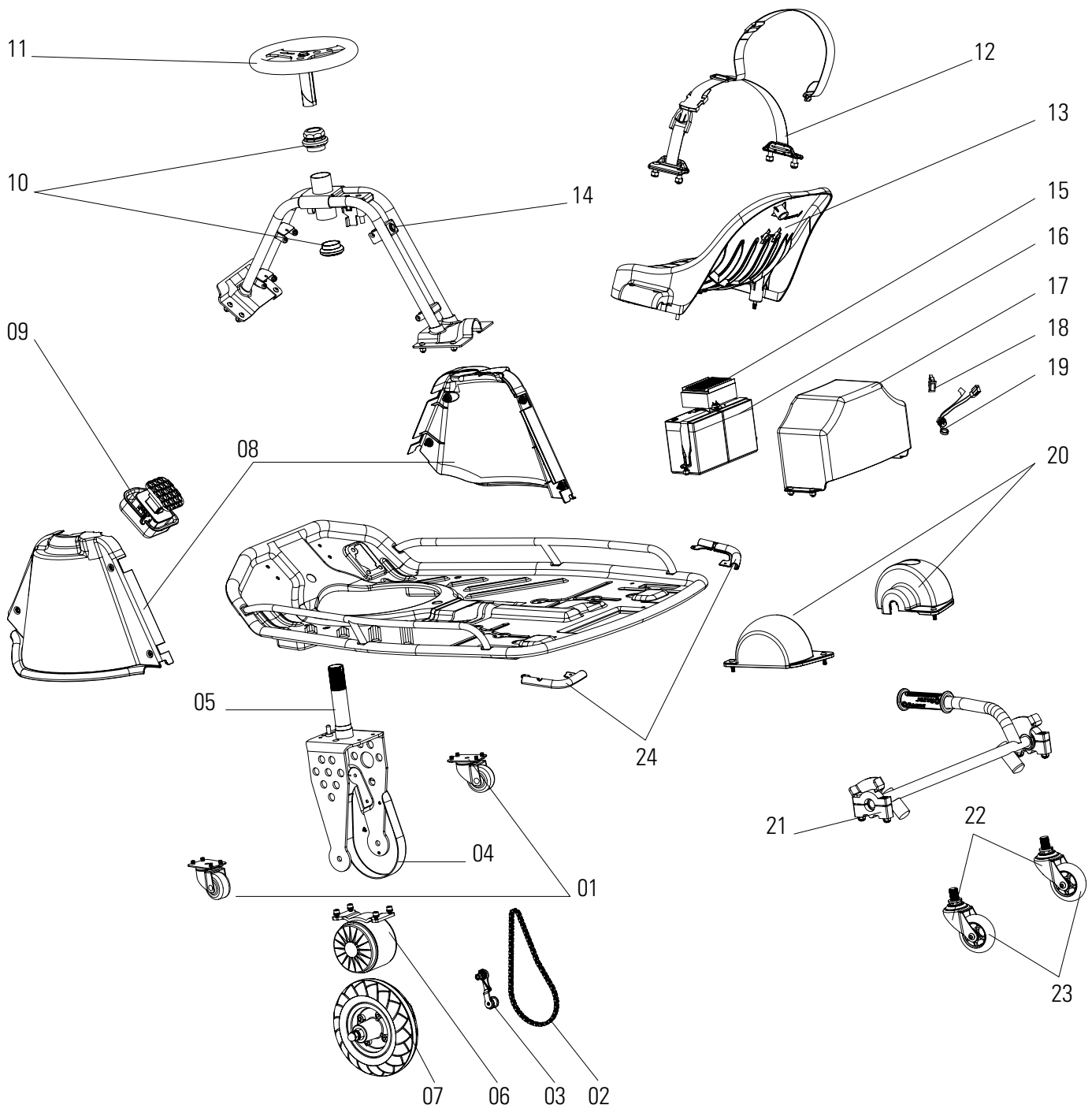

NOTICE: INSURANCE

YOUR INSURANCE POLICIES MAY NOT PROVIDE COVERAGE FOR ACCIDENTS INVOLVING THE USE OF THIS SCOOTER/ELECTRIC RIDE-ON PRODUCT. TO DETERMINE IF COVERAGE IS PROVIDED, YOU SHOULD CONTACT YOUR INSURANCE COMPANY OR AGENT.

FCC COMPLIANCE

This device complies with Part 15 of the FCC Rules. Operation is subject to the following two conditions: (1) This device may not cause harmful interference, and (2) this device must accept any interference received, including interference that may cause undesired operation.

Note: This equipment has been tested and found to comply with the limits for a Class B digital device, pursuant to part 15 of the FCC Rules. These limits are designed to provide reasonable protection against harmful interference in a residential installation. This equipment generates, uses and can radiate radio frequency energy and, if not installed and used in accordance with the instructions, may cause harmful interference to radio communications. However, there is no guarantee that interference will not occur in a particular installation. If this equipment does cause harmful interference to radio or television reception, which can be determined by turning the equipment off and on, the user is encouraged to try to correct the interference by one or more of the following measures:

- Reorient or relocate the receiving antenna.
- Increase the separation between the equipment and receiver.
- Connect the equipment into an outlet on a circuit different from that to which the receiver is connected.
- Consult the dealer or an experienced radio/TV technician for help.

⚠ WARNING: Changes or modifications to this unit not expressly approved by the party responsible for compliance, could void the user's authority to operate the equipment.

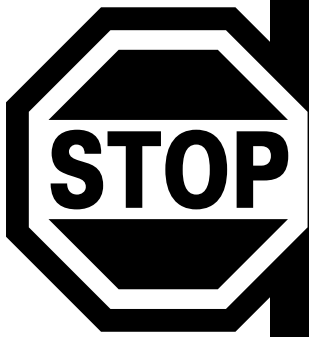

DO NOT RETURN TO STORE

Do not use this product for the first time until you have charged the battery for at least 12 hours.

Failure to follow these instructions may damage your product and void your warranty.

WARRANTY

Razor Limited Warranty

The manufacturer warrants this product to be free of manufacturing defects for a period of 90 days from date of purchase. This Limited Warranty does not cover normal wear and tear, wheels, cables, or any damage, failure or loss caused by improper assembly, maintenance, storage or use of the Razor Crazy Cart.

This Limited Warranty will be void if the product is ever

- used in a manner other than for recreation;
- modified in any way;
- rented.

The manufacturer is not liable for incidental or consequential loss or damage due directly or indirectly to the use of this product.

Razor does not offer an extended warranty. If you have purchased an extended warranty, it must be honored by the store at which it was purchased.

For your records, save your original sales receipt with this manual and write the serial number below.

Need Help? Visit our website for replacement parts and product support at www.razor.com or call toll-free at 866-467-2967 Monday - Friday 8:00 AM - 5:00 PM Pacific Time. Please have the product I.D. code (located on the bottom of the frame) available for better assistance.

Patent Pending.

Printed in China for:
Razor USA LLC
PO Box 3610
Cerritos, CA 90703

Copyright © 2003 - 2013 Razor USA LLC. All rights reserved. RAZOR and the Razor Logo Design are among the registered trademarks of Razor USA LLC in the United States and/or select foreign countries. Crazy Cart™ is a trademark of Razor USA LLC.