



**Twisti™ Ride-on**



## **OWNER'S MANUAL**

**Read and understand this entire manual before allowing child to use this product! For assistance contact Razor.  
DO NOT RETURN TO STORE.**

**NOTE: Manual illustrations are for demonstration purposes only.  
Illustrations may not reflect exact appearance of actual product.  
Specifications subject to change without notice.**

**Please have your 22 character product I.D. code ready before contacting Razor for  
warranty assistance and/or replacement parts.**

**Product I.D. Code: \_\_\_\_\_ - \_\_\_\_\_ - \_\_\_\_\_**

# CONTENTS

Safety Warnings/Usage..... 1  
Repair and Maintenance..... 2

Parts Breakdown..... 2  
Safety Reminders/Warranty..... 3

# SAFETY WARNINGS

## **⚠ AN IMPORTANT MESSAGE TO PARENTS:**

Razor® Jr products are intended to allow younger children to learn and to enjoy their early experiences using ride-on toys. Adult supervision is required as children learn and grow because children do not understand the risks of riding and are at a very high risk of falling and injuring themselves.

This manual contains important information. For your child's safety, it is your responsibility to review this information and make sure that you instruct your child to follow all warnings, cautions, instructions and safety topics. Razor USA recommends that you periodically review and reinforce the information in this manual with younger riders and that you inspect and maintain your child's Razor Jr ride-on to insure their safety.

- Do not allow children under age 18 months to use the ride-on. Close adult supervision is required.
- This product has no brake. Place feet on floor to stop.
- Always wear closed toe shoes.
- Ride on smooth surfaces.
- Do not exceed 44 lb (20 kg) total weight on the Razor Jr ride-on.
- Rider weight does not necessarily mean a child's size is appropriate to fit or maintain control of the ride-on.

- A parent's decision to allow his or her child to ride this product should be based on the child's maturity and skill.
- Only ride Twisti while seated.
- Never attempt to mount or dismount product while it is moving.

## **ACCEPTABLE INDOOR RIDING PRACTICES AND CONDITIONS**

Direct parental supervision is required at all times. Ride-ons are meant to be used only in controlled environments. Child must maintain a hold on the handlebars at all times. Never allow more than one child at a time to ride a ride-on. Never use near steps, sloped driveways, hills, roadways, alleys or swimming pool areas. Do not use the Twisti on a hill, steep slope, over rough terrain or uneven surfaces.

FAILURE TO USE COMMON SENSE AND HEED THE ABOVE WARNINGS FURTHER INCREASES RISK OF SERIOUS INJURY. USE AT YOUR OWN RISK AND WITH APPROPRIATE AND SERIOUS ATTENTION TO SAFE OPERATION. USE CAUTION.

**⚠ WARNING:** ALWAYS INSPECT RIDE-ON PRIOR TO RIDING. Properly inspecting and maintaining your ride-on can reduce the risk of injury. Always inspect your ride-on before riding and regularly maintain it. Replace worn parts when they occur.

# USAGE

## **□ How to Ride**

While seated, grasp hand grips and place both feet on the front of the motion bar. Using hands and feet move the bar from side to side to propel the product. Learn with a parent's help.



## **□ How to Stop**

Place feet on floor to stop. Make certain feet are placed on the sides (not in front) of seat before dismounting to either side.

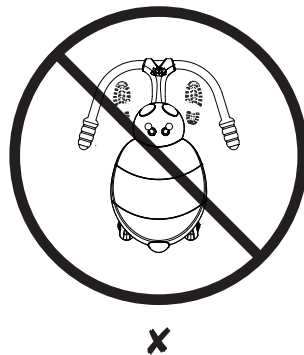
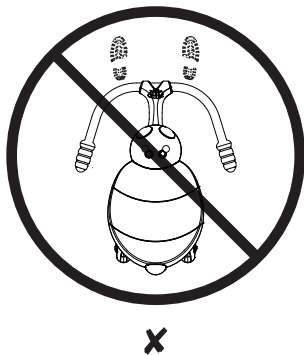
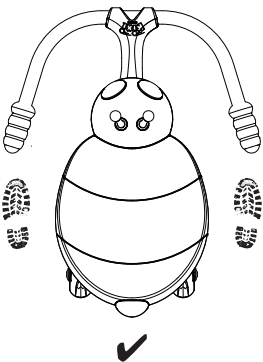

## REPAIR AND MAINTENANCE

### ❑ Wheels

Under normal circumstances and conditions, Razor wheels are maintenance free. Nonetheless, it is the responsibility of the owner or guardian to periodically inspect the wheels for wear and tear, the axle for proper tightness, and for loose parts. When a wheel develops play, this is an indication of excess wear and replacement is necessary. Replace immediately with only genuine Razor wheels. Worn wheels are considered normal wear-and-tear and are not covered by the Razor Warranty. Wheels other than genuine Razor wheels may not be compatible with your Razor Jr ride-on. The use of anything other than genuine Razor replacement parts may affect your safety and will void your warranty.

### ❑ Cleaning Your Ride-on

Wipe with a damp cloth to remove dirt and dust. Do not use industrial cleaners or solvents, as they may damage the surfaces. Do not use alcohol, alcohol-based or ammonia-based cleaners, as they may damage or dissolve the plastic components or soften the decals or decal adhesive.

### PRODUCT I.D. CODE

1. Underneath Seat
2. UPC Side of Box (not shown)

## TWISTI PARTS

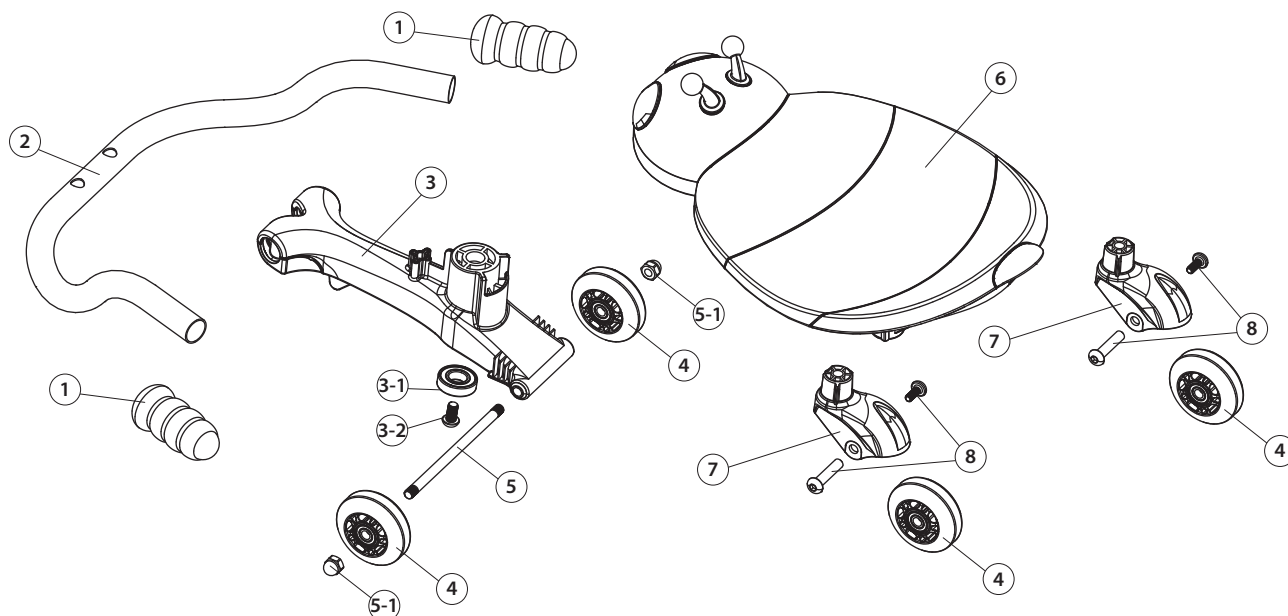

1. Handlebar Grips (2)

2. Motion Bar

3. Pivot Arm

3-1. Bearing

3-2. 5 mm Hex Bolt

4. 64 mm Front/Rear Wheels (4)

5. Front Axle Bolt

5-1. Lock Nuts (2)

6. Frame/Seat

7. Rear Wheel Covers (2)

8. Rear Axle Bolt Sets (2)

**Need Help?** Visit our web site for replacement parts and product support at [www.razor.com](http://www.razor.com) or call toll-free at 866-467-2967 Monday - Friday 8:00 AM - 5:00 PM Pacific Time. Please have the product I.D. code (located on the bottom of the seat) available for better assistance.

## SAFETY REMINDERS

### PRE-RIDE CHECKLIST



#### Loose Parts

Check and secure all fasteners before every ride. Make sure the pivoting mechanism and the plastic cover are locked properly in place before riding.



#### Replacement Parts

Replace worn or broken parts immediately. Visit [www.razor.com](http://www.razor.com) or contact Razor customer care for replacement parts.



**DO NOT RETURN TO STORE**  
Failure to follow these instructions may damage  
your product and void your warranty.

## WARRANTY

#### Razor Limited Warranty

The manufacturer warrants this product to be free of manufacturing defects for a period of 6 months from date of purchase. This Limited Warranty does not cover normal wear and tear, or any damage, failure or loss caused by improper assembly, maintenance, or storage.

This Limited Warranty will be void if the product is ever:

- used in a manner other than for recreation;
- modified in any way;
- rented.

The manufacturer is not liable for incidental or consequential loss or damage due directly or indirectly to the use of this product.

Razor does not offer an extended warranty. If you have purchased an extended warranty, it must be honored by the store at which it was purchased.

For your records, save your original sales receipt with this manual.

**Need Help?** Visit our web site for replacement parts and product support at [www.razor.com](http://www.razor.com) or call toll-free at 866-467-2967 Monday - Friday 8:00 AM - 5:00 PM Pacific Time. Please have the product I.D. code (located on the bottom of the seat) available for better assistance.

Printed in China for:  
Razor USA LLC

Copyright © 2003-2013 Razor USA, LLC. All rights reserved. Razor and the Razor Logo Design are among the registered trademarks of Razor USA LLC in the United States and/or select foreign countries. Twist™ is a trademark of Razor USA LLC.